

4

3

2

1

Item No.	Part number	Quantity	Name	Description
1	F01	2	Foot End Piece	Foot plate 12 mm thick
2	E01	2	End Piece	End plate - 12 mm thick
3	B02	1	Flat Bed	Bed Plate - 10 mm thick
4	B01	1	Bed Brace	Bed Brace - 12 mm thick
5		3	PH Countersunk flat head screw ISO 7046-1	Counter Sunk M8 x 20
6		8	Hex head bolt grade B ISO 4015	Hex Head M8 x 30
7	A05	2	Adjustment Plate	5 mm Thick plate
8	S01	2	3/4 Shaft	20 mm Dia Round Bar
9	L01	1	Lifting Plate	20 mm thick plate
10	B03	1	Bending Brace	12 x 25 mm Bar
11	H01	1	Bender Handle	20 mm Round Bar
12		2	Chamfered plain washer normal M8	Chamfered plain washer normal M8 Steel
13		2	Hex head screw grade C M8x1.25 x 16	Hex head screw grade C M8x1.25 x 16 Stainless Steel
14	A03	2	Arm	10 mm thick plate
15	A02	4	Adjuster Nut	30 mm AF Hex Bar
16	A04	1	Unequal Angle	65 x 50 x 6 mm Angle
17	F03	3	75 mm finger	10 mm thick plate
18	F05	2	50 mm finger	10 mm thick plate
19	F02	2	35 mm finger	10 mm thick plate
20	R01	9	Finger retainer	10 mm thick plate
21		10	Hex head screw grade C M8x1.25 x 25	Hex head screw grade C M8x1.25 x 25 Steel
22	F04	1	150 mm finger	10 mm thick plate
23		4	Hex head screw grade C M8x1.25 x 40	Hex head screw grade C M8x1.25 x 40 Steel
24	C01	2	Con rod	10 mm thick plate
25	A01	1	Axle	20 mm Dia Round Bar
26	P01	2	Pivot	60 mm Dia Round Bar
27	B04	2	Bush	PLASTIC 35 mm Dia Round
28	H02	1	Clamp Handle	25 mm OD pipe and a bit of 3 mm plate

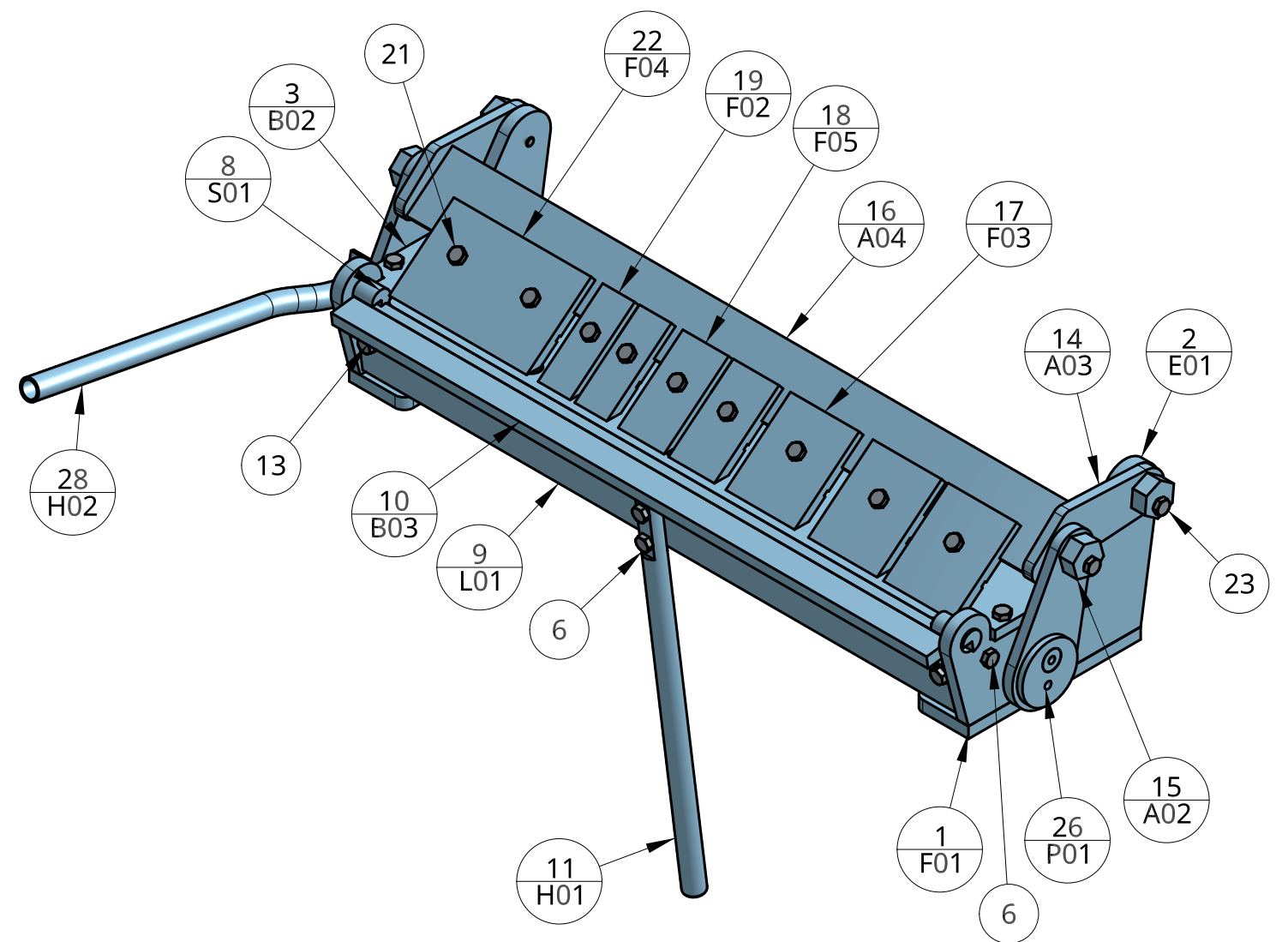

UNLESS OTHERWISE SPECIFIED, DIMENSIONS ARE IN MILLIMETERS

ANGULAR = ± °

SURFACE FINISH

DO NOT SCALE DRAWING

BREAK ALL SHARP EDGES AND REMOVE BURRS

THIRD ANGLE PROJECTION

	NAME	DATE
DRAWN	BRENDAN HAMPSHIRE	07/23/2019
CHECKED		
APPROVED		

TITLE		
PAN BREAK ASSEMBLY AND BOQ		
SIZE	DWG NO.	REV.
B	001	
SCALE	WEIGHT	SHEET
1:5		1 of 1

4

3

2

1

D

D

C

C

B

B

A

A

4

3

2

1

D

D

C

C

B

B

A

A

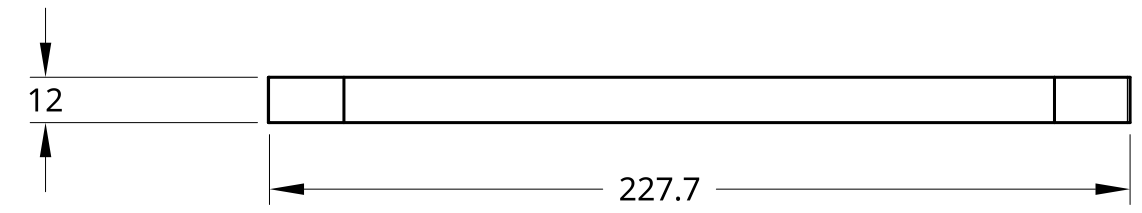
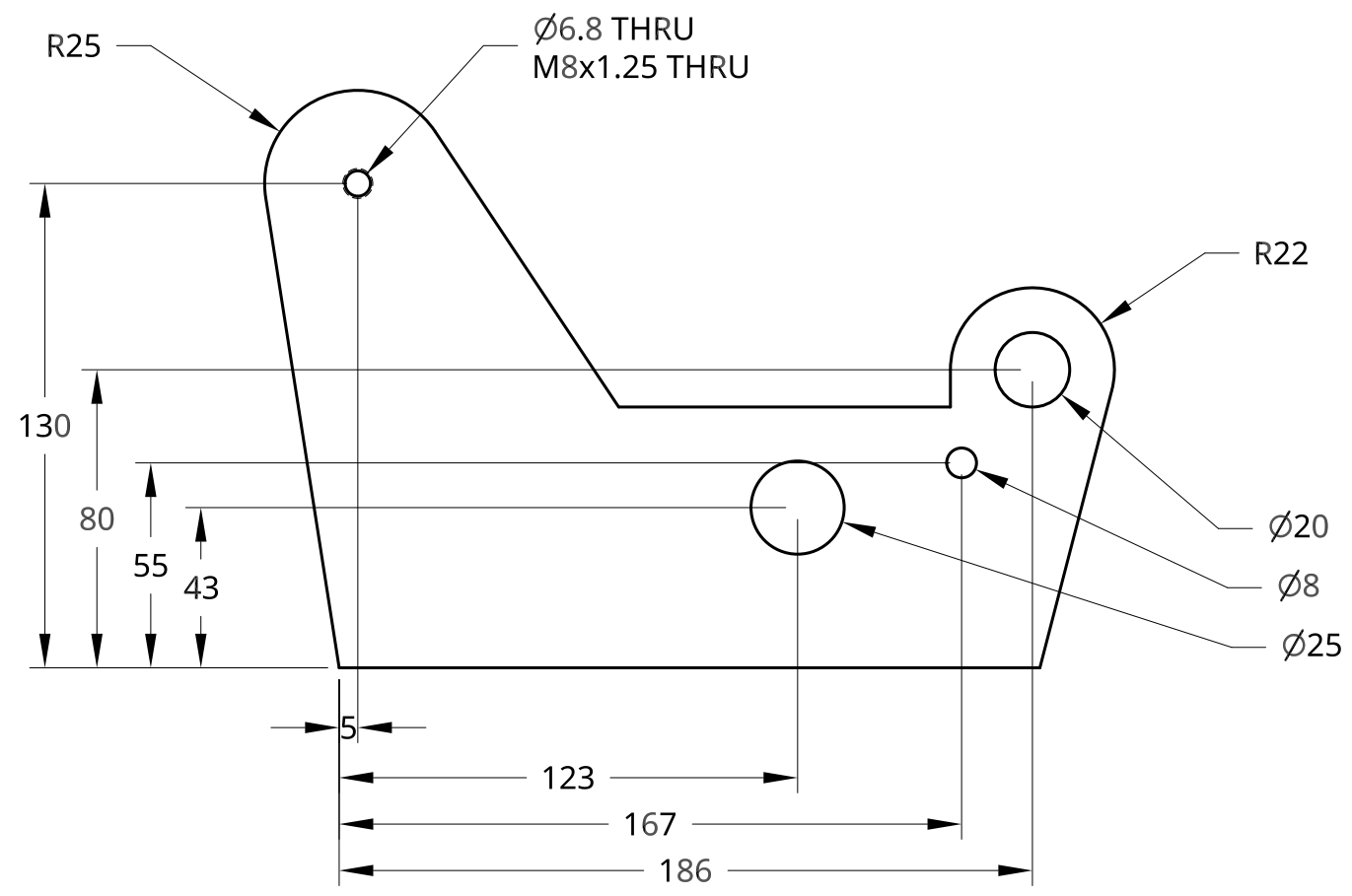

PART NO. E01 - END PIECE
2x Required

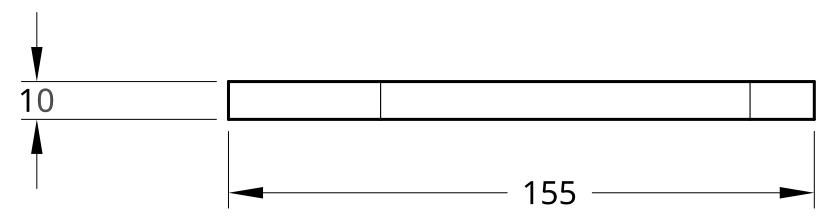
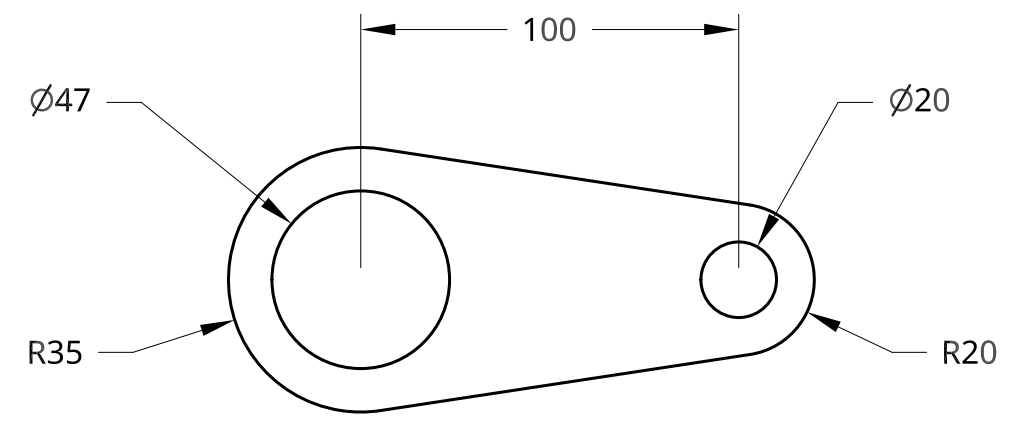

PART NO. C03 - CONNECTING ROD
2x Required

UNLESS OTHERWISE SPECIFIED, DIMENSIONS ARE IN MILLIMETERS ANGULAR = ± ° SURFACE FINISH DO NOT SCALE DRAWING BREAK ALL SHARP EDGES AND REMOVE BURRS THIRD ANGLE PROJECTION 	NAME	DATE	TITLE					
	DRAWN	BRENDAN HAMPSHIRE				07/15/2019	END PLATE AND CONNECTING ROD	
	CHECKED							
	APPROVED			SIZE	DWG NO.	REV.		
	MATERIAL	FINISH		B	002			
			SCALE	1:2	WEIGHT	SHEET	1 of 1	

4

3

2

1

4

3

2

1

D

D

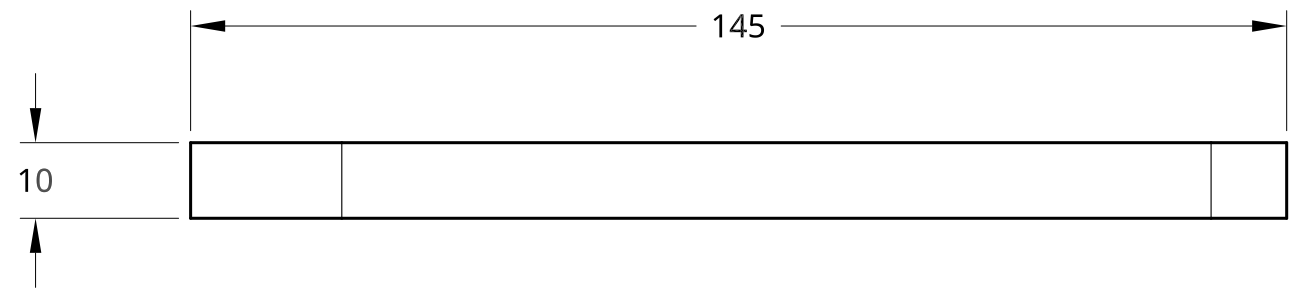
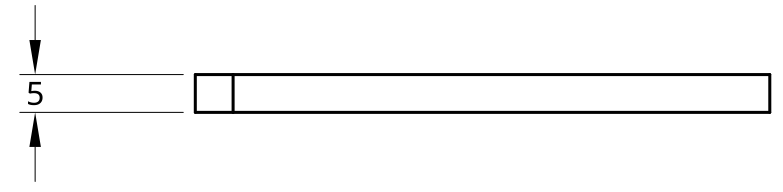

C

C

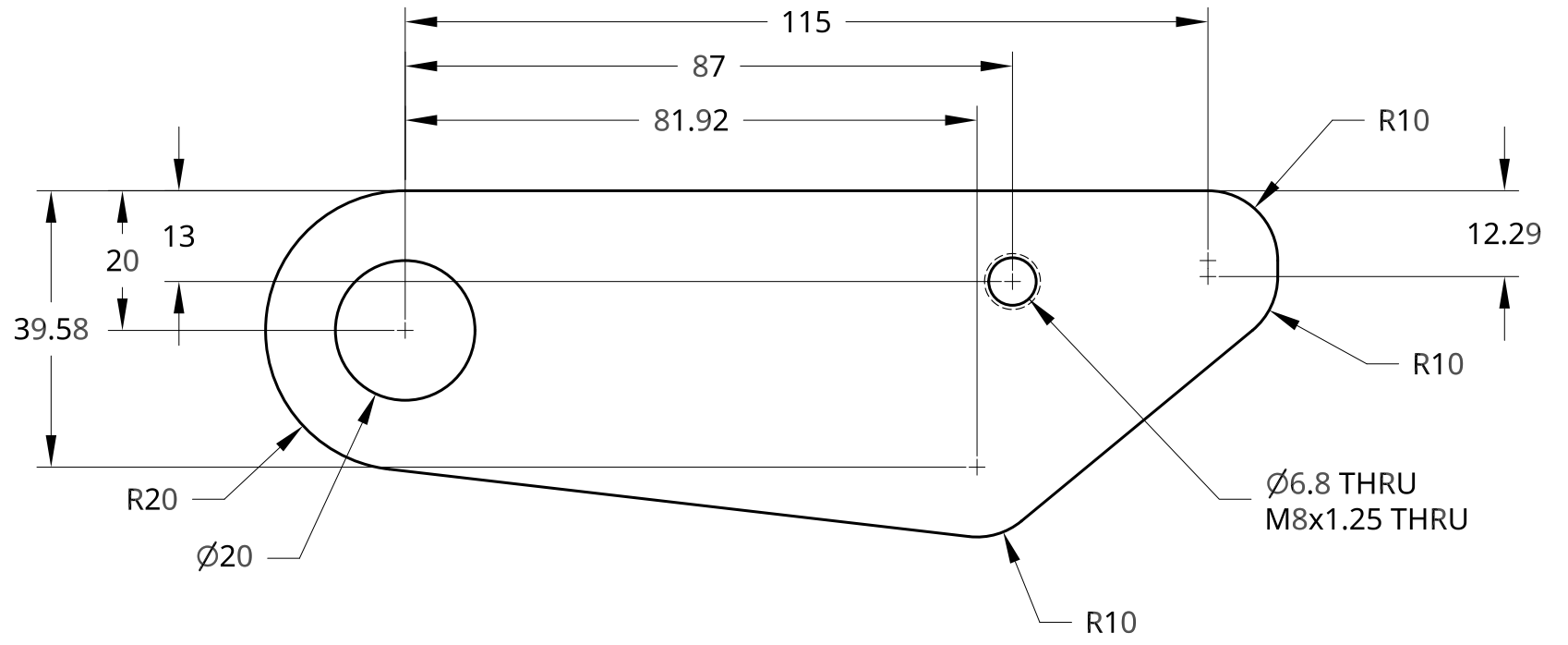
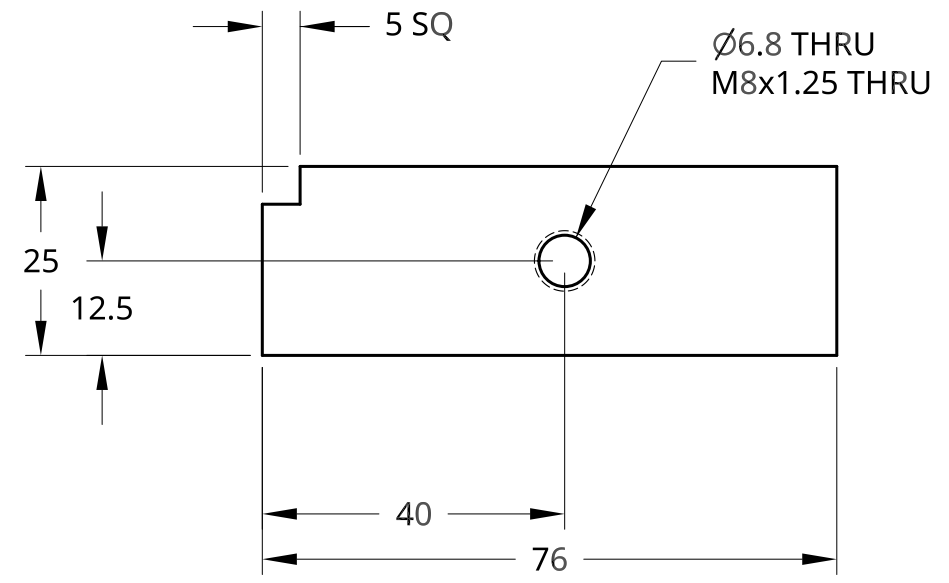

B

B

PART NO. A05 - ADJUSTMENT PLATE
2x Required

PART NO. A03 - ARM
2x Required

A

A

UNLESS OTHERWISE SPECIFIED, DIMENSIONS ARE IN MILLIMETERS ANGULAR = ± ° SURFACE FINISH DO NOT SCALE DRAWING BREAK ALL SHARP EDGES AND REMOVE BURRS THIRD ANGLE PROJECTION 	NAME	DATE	TITLE			
	DRAWN	BRENDAN HAMPSHIRE			07/15/2019	
	CHECKED					
	APPROVED			ADJUSTMENT PLATE AND ARM		
	MATERIAL	FINISH	SIZE			DWG NO.
		B	003			
		SCALE	1:1	WEIGHT	SHEET	1 of 1

4

3

2

1

4

3

2

1

D

D

C

C

B

B

A

A

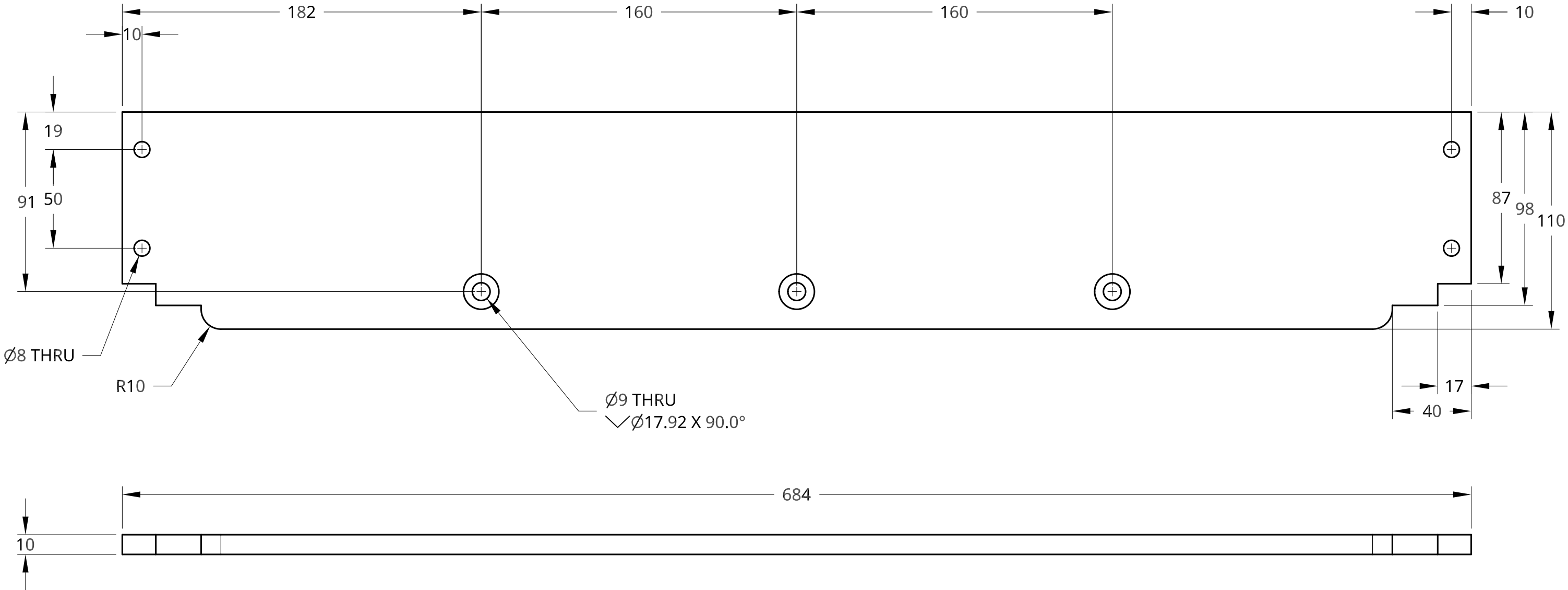

PART NO. B02 - FLAT BED
1x Required

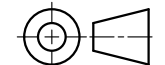
UNLESS OTHERWISE SPECIFIED, DIMENSIONS ARE IN MILLIMETERS ANGULAR = \pm ° SURFACE FINISH \surd DO NOT SCALE DRAWING BREAK ALL SHARP EDGES AND REMOVE BURRS THIRD ANGLE PROJECTION 		NAME	DATE	TITLE FLAT BED		
	DRAWN	BRENDAN HAMPSHIRE	07/15/2019			
	CHECKED					
	APPROVED					
	MATERIAL	FINISH	SIZE B	DWG NO. 004	REV.	
		SCALE 1:2	WEIGHT	SHEET 1 of 1		

4

3

2

1

D

D

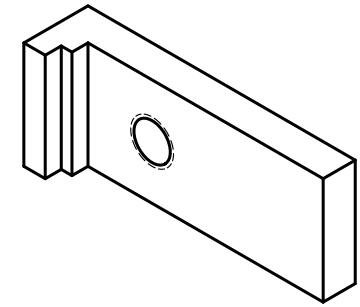
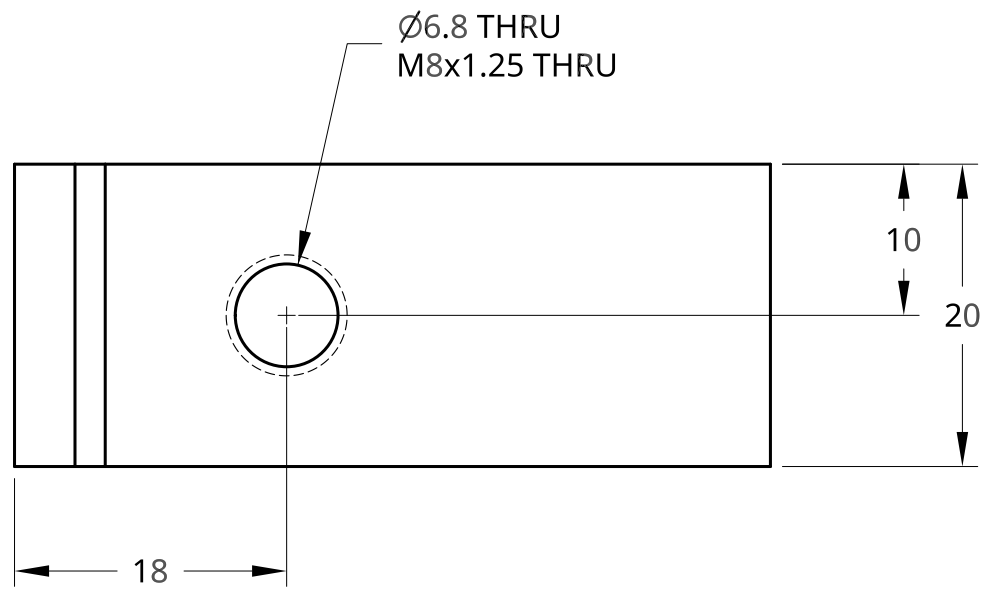
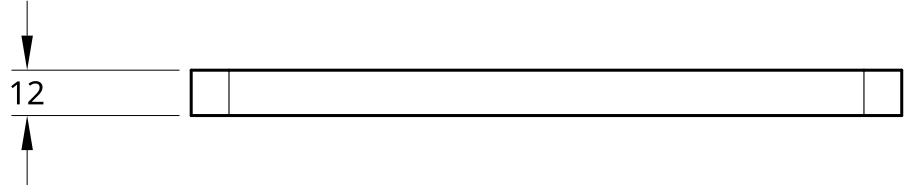

3D for clarity only

C

C

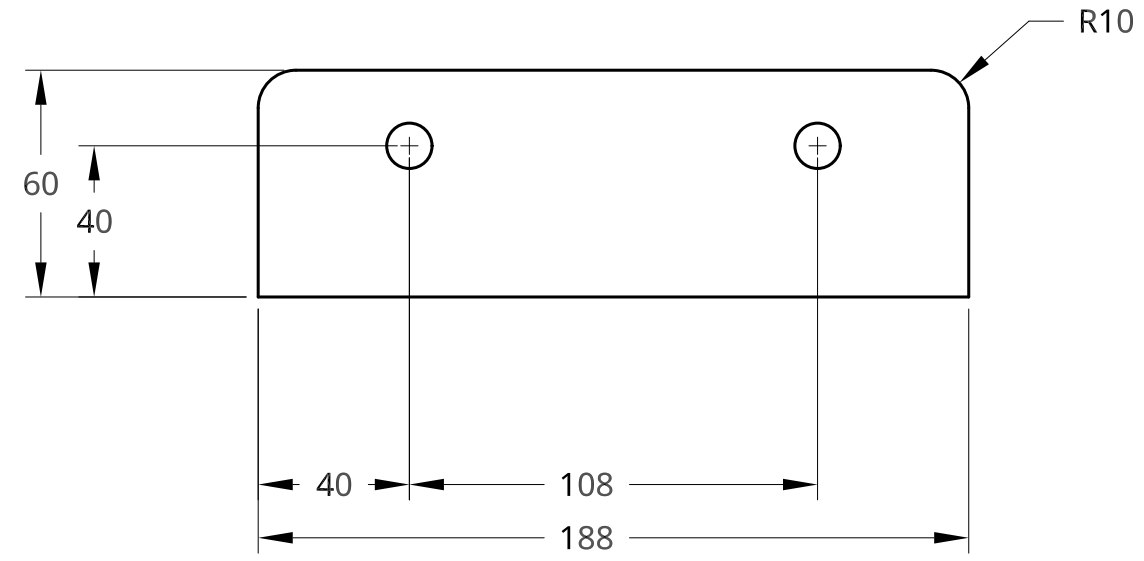

PART NO. F01 - FOOT PLATE
2x Required

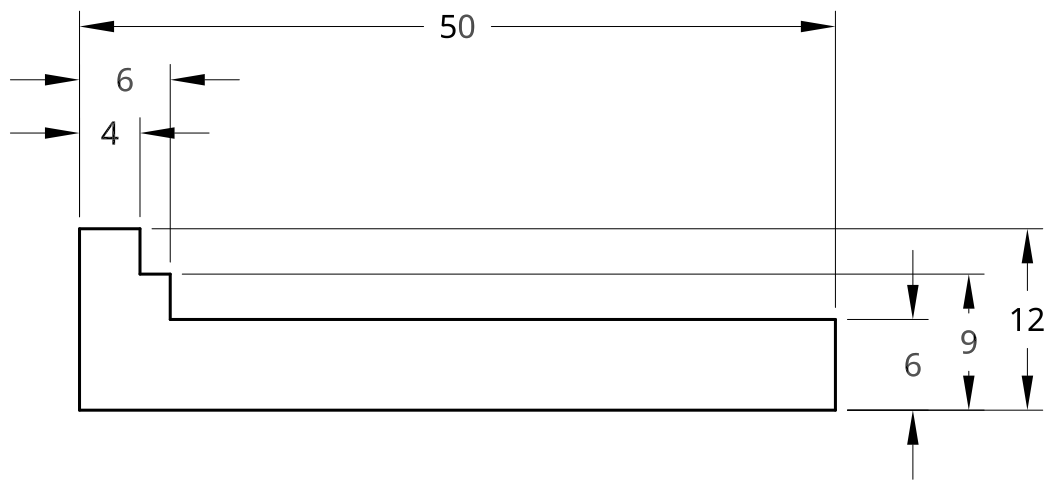

PART NO. R01 - FINGER RETAINER
As many as you need.
Say 5. Na, fuck it, 11

B

B

A

A

UNLESS OTHERWISE SPECIFIED, DIMENSIONS ARE IN MILLIMETERS ANGULAR = ± ° SURFACE FINISH DO NOT SCALE DRAWING BREAK ALL SHARP EDGES AND REMOVE BURRS THIRD ANGLE PROJECTION 		NAME	DATE	TITLE FOOT PLATE AND FINGER RETAINER		
	DRAWN	BRENDAN HAMPSHIRE	07/15/2019			
	CHECKED					
	APPROVED			SIZE B	DWG NO. 005	REV.
		MATERIAL	FINISH	SCALE 1:2	WEIGHT	SHEET 1 of 1

4

3

2

1

4

3

2

1

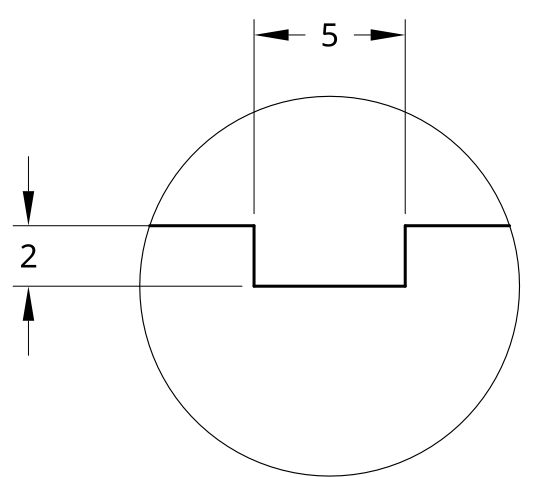
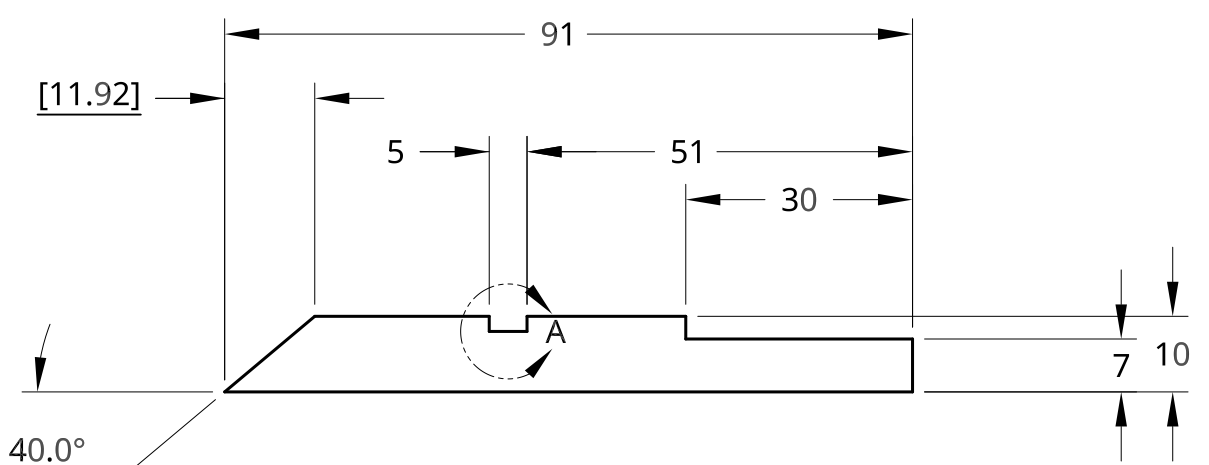
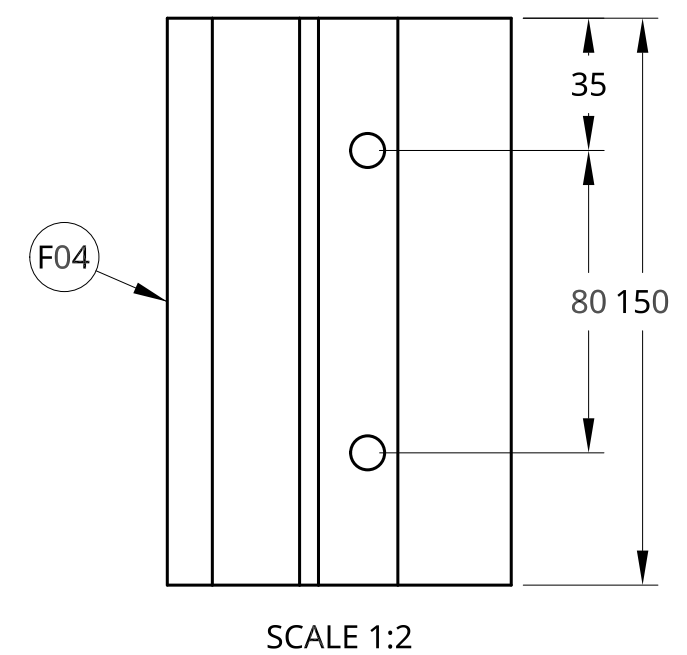
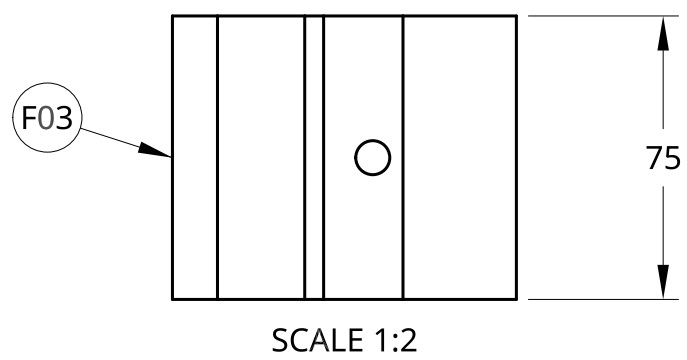
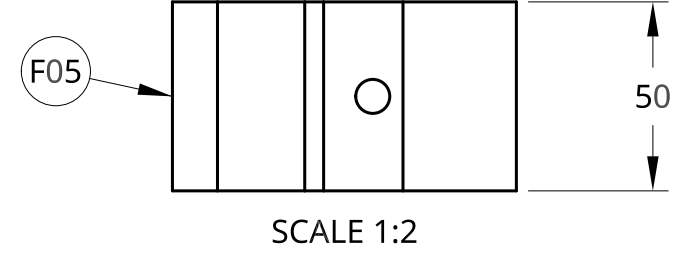
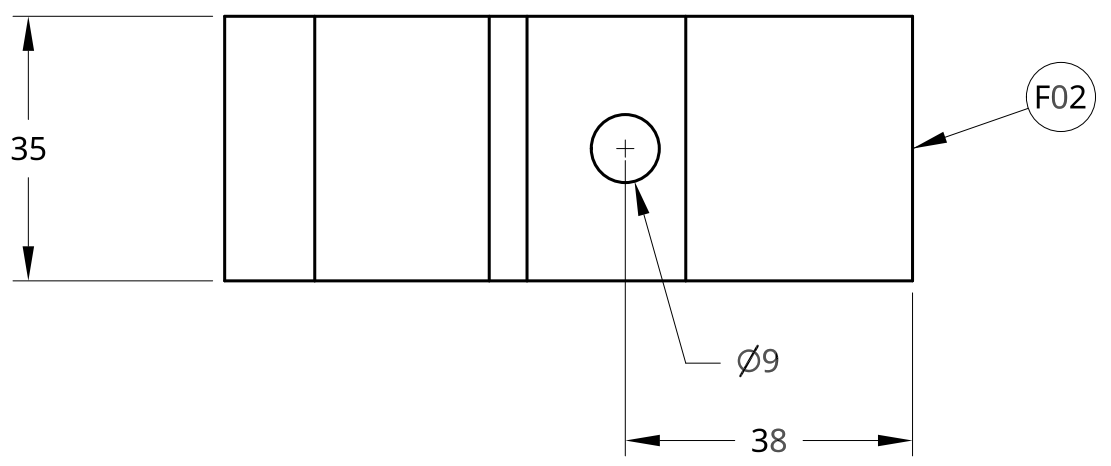

DETAIL A
SCALE 4:1

PART NO. F02, F03, F04 AND F05 - FINGERS
As Many as you want
Same profile, different widths..

UNLESS OTHERWISE SPECIFIED, DIMENSIONS ARE IN MILLIMETERS		NAME	DATE		
ANGULAR = ± °		DRAWN	BRENDAN HAMPSHIRE	07/15/2019	
SURFACE FINISH		CHECKED			TITLE
DO NOT SCALE DRAWING		APPROVED			FINGERS
BREAK ALL SHARP EDGES AND REMOVE BURRS					
THIRD ANGLE PROJECTION		MATERIAL	FINISH	SIZE	DWG NO.
				B	006
				SCALE	WEIGHT
				1:1	1 of 1
				SHEET	REV.

4

3

2

1

D

D

C

C

B

B

A

A

4

3

2

1

D

D

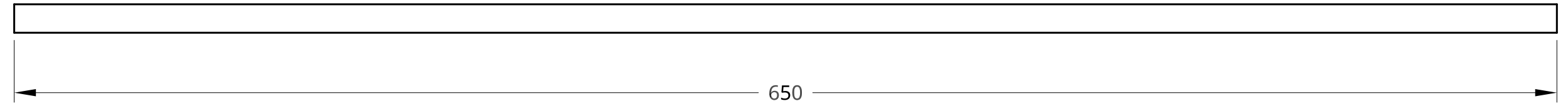
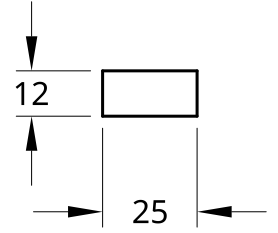

PART NO. B03 - BENDING BRACE
1x Required

C

C

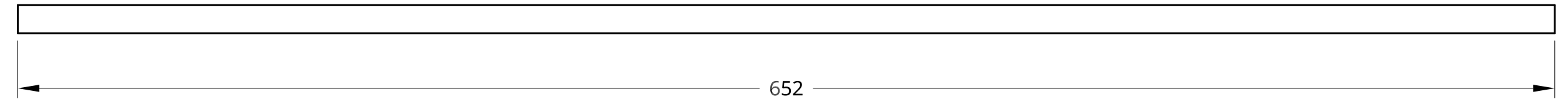
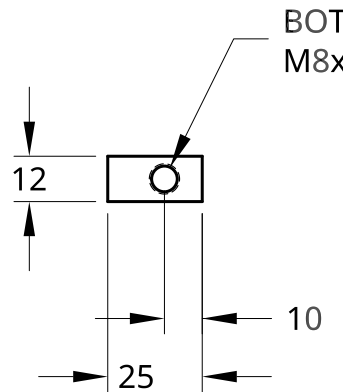

PART NO. B01 - BED BRACE
1x Required

B

B

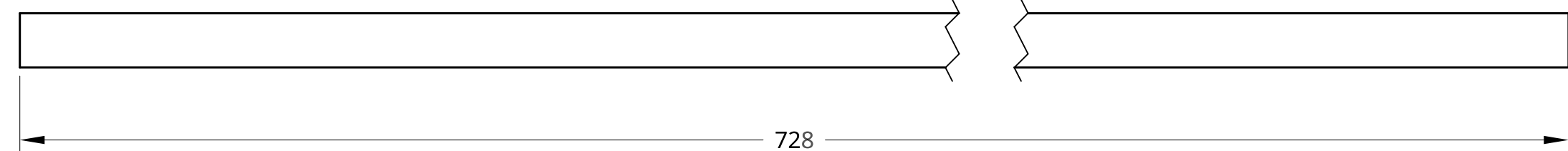
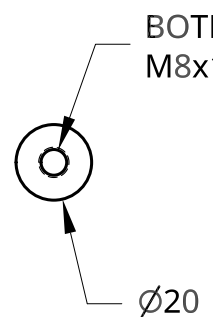

PART NO. A01 - AXLE
1x Required

A

A

UNLESS OTHERWISE SPECIFIED,
DIMENSIONS ARE IN MILLIMETERS

ANGULAR = \pm °

SURFACE FINISH

DO NOT SCALE DRAWING

BREAK ALL SHARP EDGES AND
REMOVE BURRS

THIRD ANGLE PROJECTION

	NAME	DATE
DRAWN	BRENDAN HAMPSHIRE	07/23/2019
CHECKED		
APPROVED		
MATERIAL	FINISH	

TITLE		
BENDING BRACE, BED BRACE AND AXLE.		
SIZE	DWG NO.	REV.
B	007	
SCALE	WEIGHT	SHEET
1:2		1 of 1

4

3

2

1

4

3

2

1

D

D

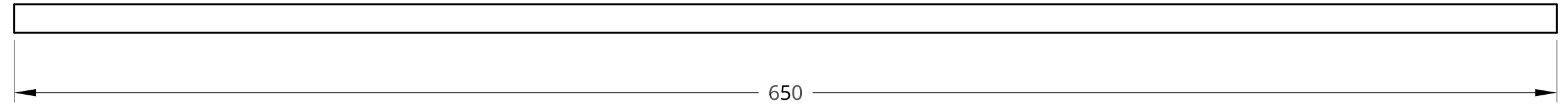
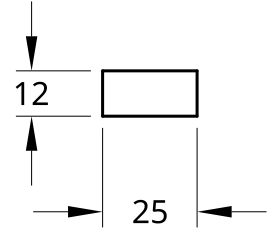

PART NO. B03 - BENDING BRACE
1x Required

C

C

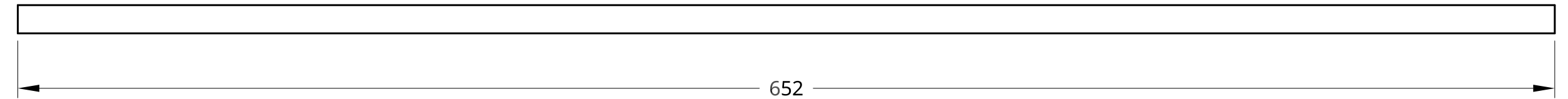
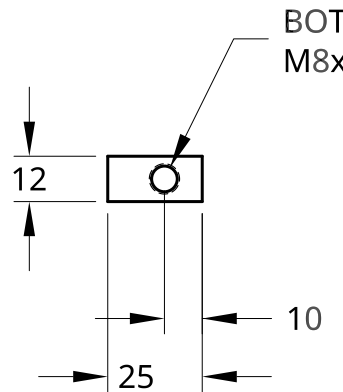

PART NO. B01 - BED BRACE
1x Required

B

B

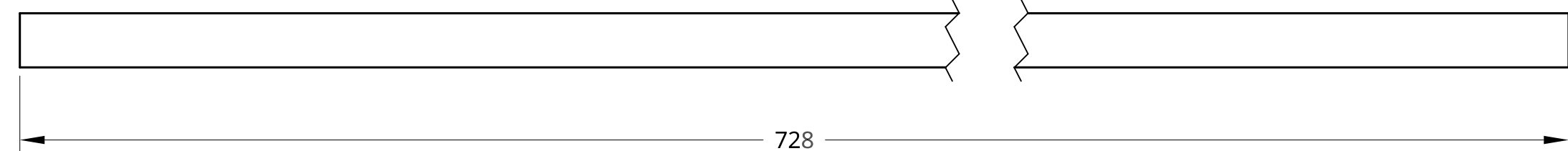
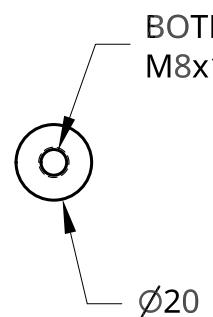

PART NO. A01 - AXLE
1x Required

A

A

UNLESS OTHERWISE SPECIFIED,
DIMENSIONS ARE IN MILLIMETERS

ANGULAR = \pm °

SURFACE FINISH

DO NOT SCALE DRAWING

BREAK ALL SHARP EDGES AND
REMOVE BURRS

THIRD ANGLE PROJECTION

	NAME	DATE
DRAWN	BRENDAN HAMPSHIRE	07/23/2019
CHECKED		
APPROVED		
MATERIAL	FINISH	

TITLE		
BENDING BRACE, BED BRACE AND AXLE.		
SIZE	DWG NO.	REV.
B	007	
SCALE	WEIGHT	SHEET
1:2		1 of 1

4

3

2

1

6

5

4

3

2

1

D

D

C

C

B

B

A

A

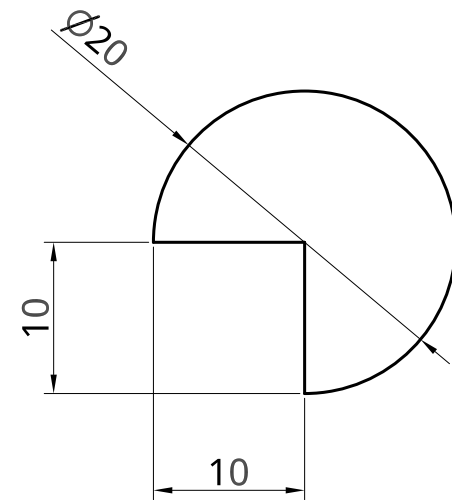
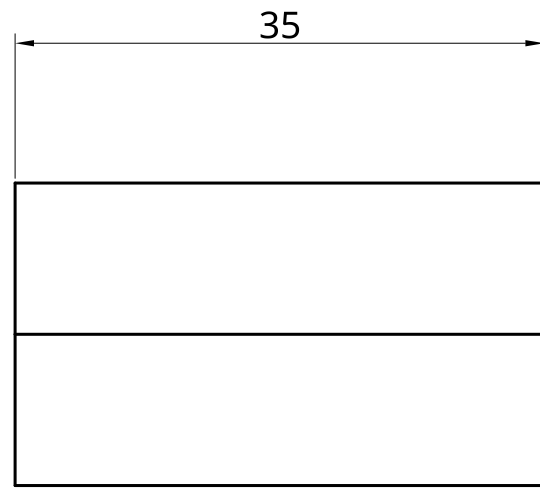

PART NO. S01 - 3/4 SHAFT
2 OFF REQUIRED

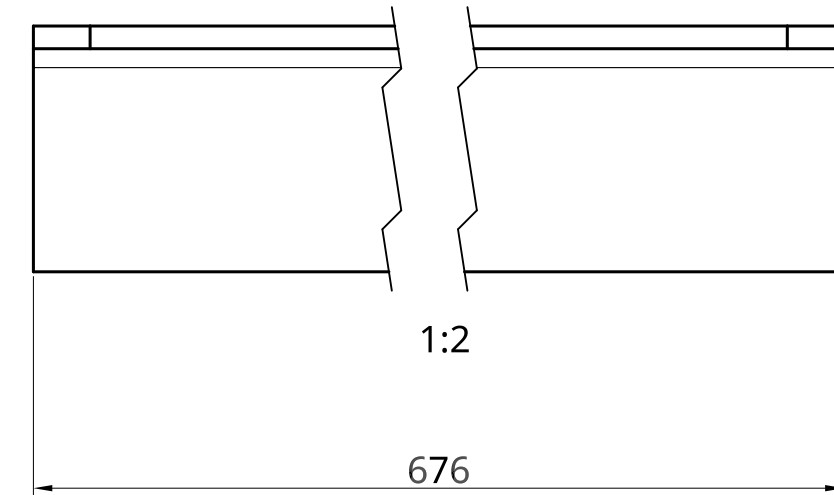
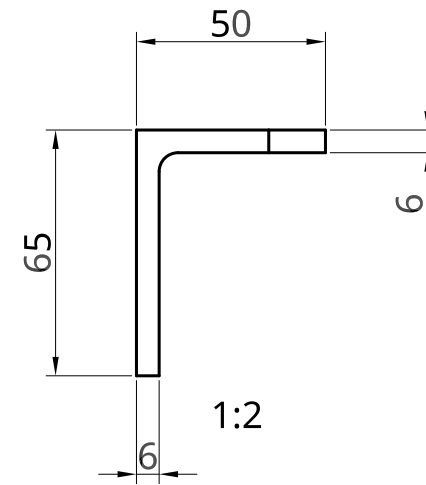
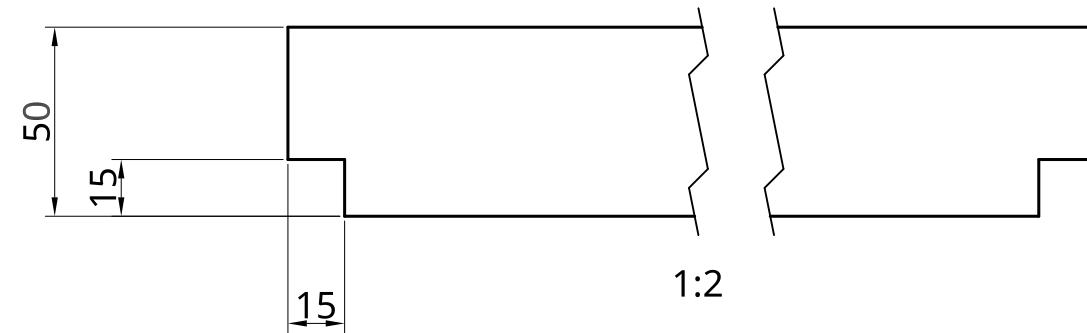

PART NO. A04 - UNEQUAL ANGLE
1 OFF REQUIRED

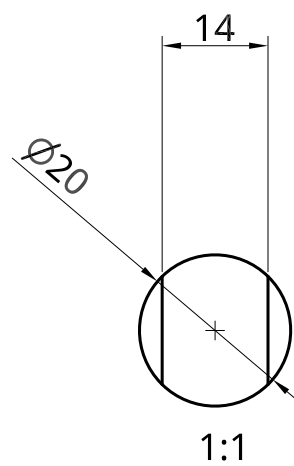
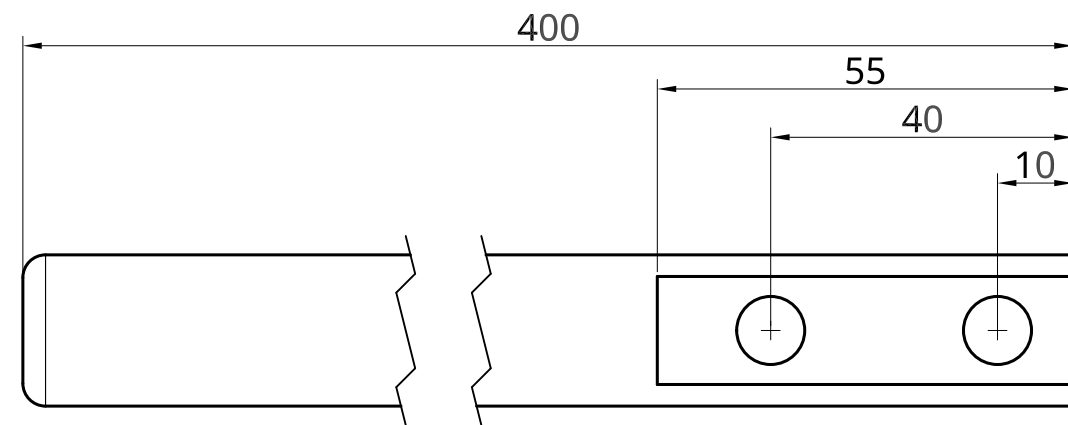

PART NO. H01 - BENDER HANDLE
1 OFF REQUIRED

UNLESS OTHERWISE SPECIFIED, DIMENSIONS ARE IN MILLIMETERS		NAME	SIGNATURE	DATE	TITLE 3/4 SHAFT, BENBER HANDLE AND UNEQUAL ANGLE	
ANGULAR = ± °		DRAWN	BRENDAN HAMPSHIRE	2020-05-23		
SURFACE FINISH		CHECKED				
DO NOT SCALE DRAWING		APPROVED				
BREAK ALL SHARP EDGES AND REMOVE BURRS		MATERIAL	FINISH		SIZE A3	DWG NO. 008
THIRD ANGLE PROJECTION				SCALE 2:1	WEIGHT	SHEET 1 of 1

6

5

4

3

2

1

6 5 4 3 2 1

D

D

C

C

B

B

A

A

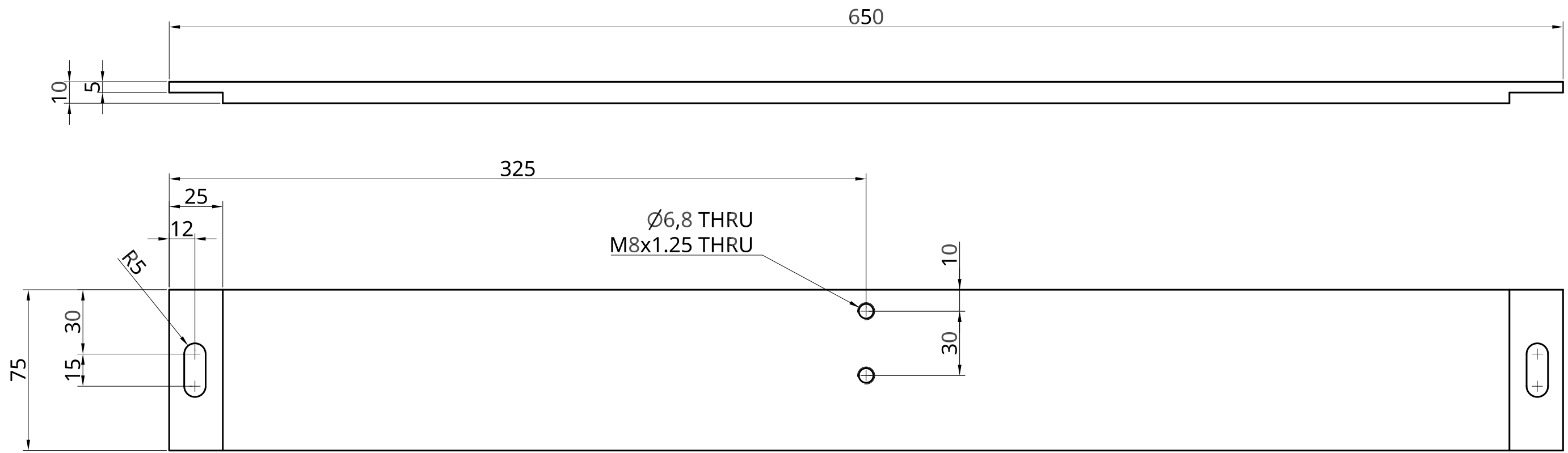

PART NO. L01 - LIFTING PLATE
1 OFF REQUIRED

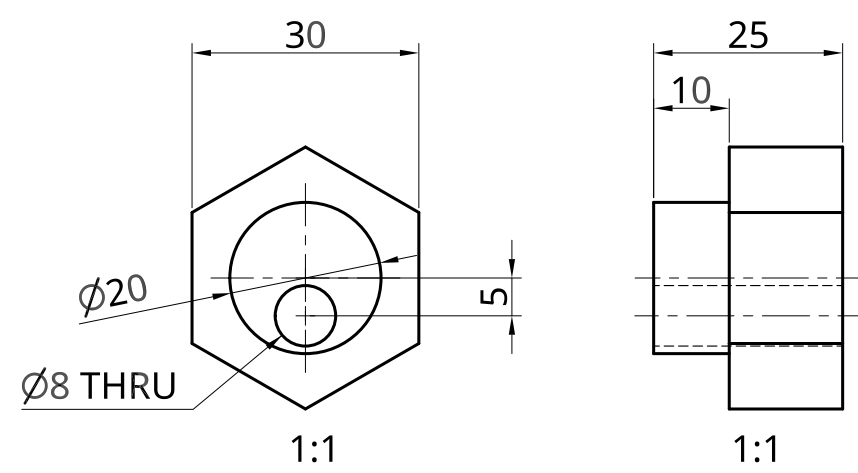

PART NO. A02 - ADJUSTER NUT
4 OFF REQUIRED

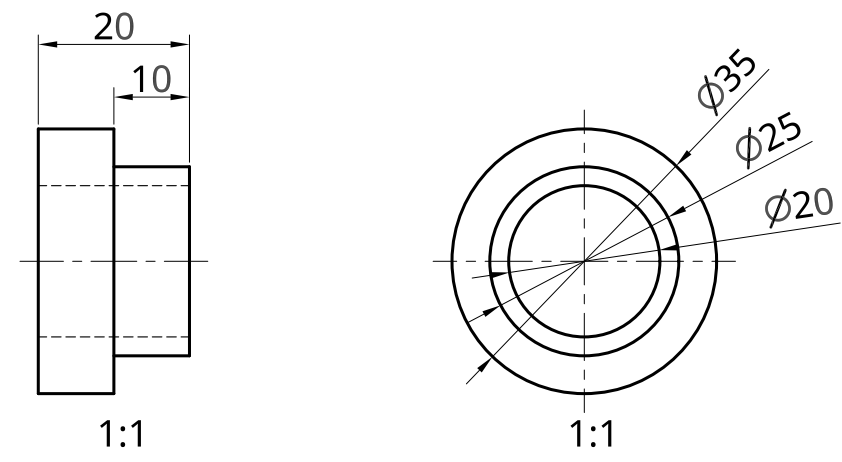

PART NO. B04 - BUSH
2 OFF REQUIRED (PLASTIC)

UNLESS OTHERWISE SPECIFIED, DIMENSIONS ARE IN MILLIMETERS	NAME	SIGNATURE	DATE	TITLE LIFTING PLATE, ADJUSTER NUT AND BUSH
	DRAWN	BRENDAN HAMPSHIRE	2020-05-24	
	CHECKED			
	APPROVED			
ANGULAR = ± °				SIZE A3
SURFACE FINISH	MATERIAL		FINISH	
DO NOT SCALE DRAWING				SCALE 1:2
BREAK ALL SHARP EDGES AND REMOVE BURRS				WEIGHT
THIRD ANGLE PROJECTION				SHEET 1 of 1

6 5 4 3 2 1

6

5

4

3

2

1

D

D

C

C

B

B

A

A

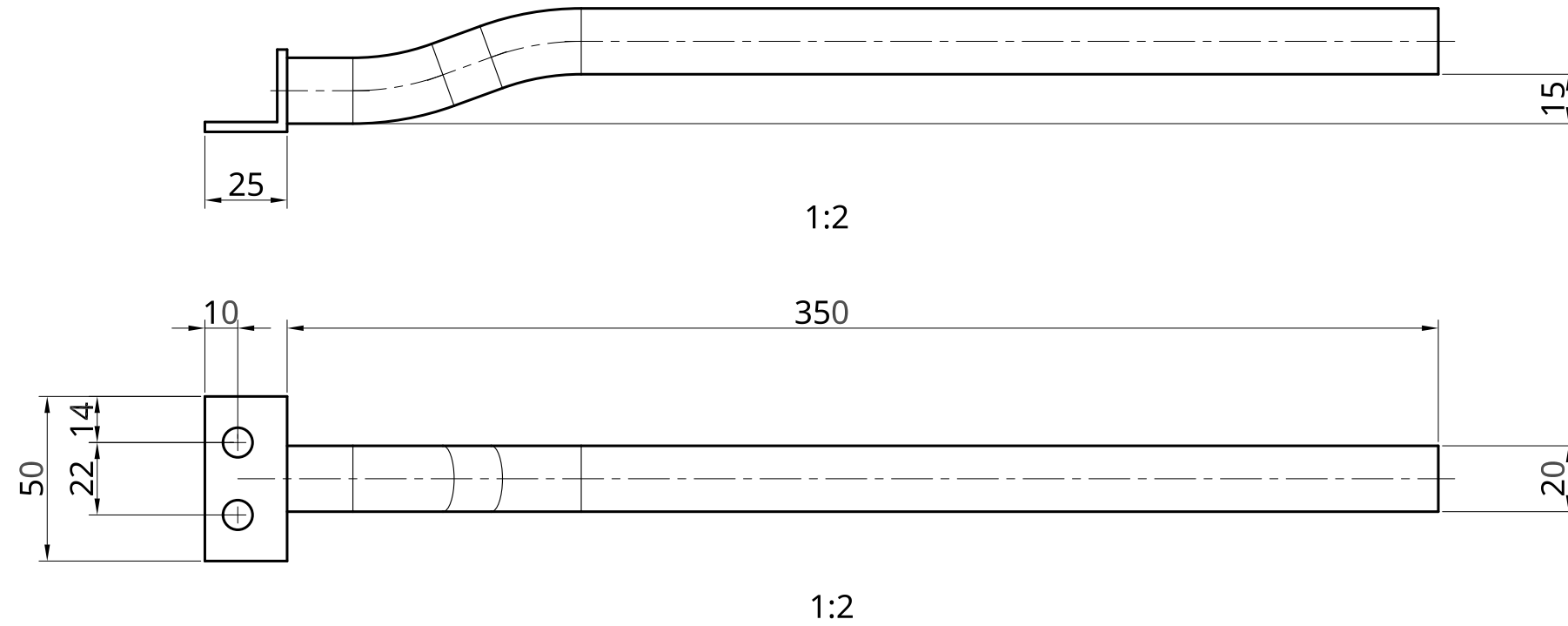

PART NO. H02 - CLAMP HANDLE

1 OFF REQUIRED

COULD BE MADE FROM ANYTHING DOESN'T NEED TO BE EXACT LIKE THIS AT ALL.

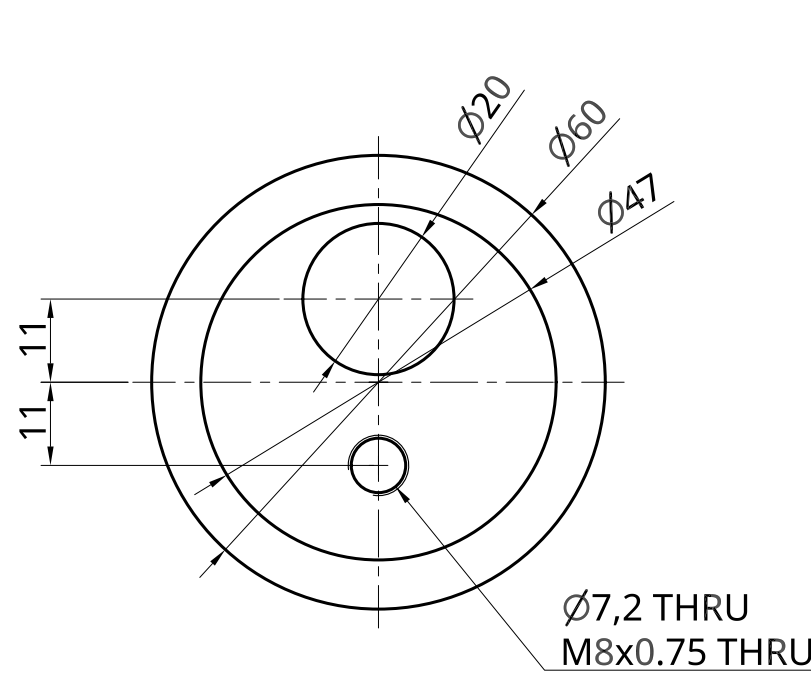

PART NO. P01 - PIVOT

2 OFF REQUIRED

UNLESS OTHERWISE SPECIFIED,
DIMENSIONS ARE IN MILLIMETERS

ANGULAR = ± °

SURFACE FINISH

DO NOT SCALE DRAWING

BREAK ALL SHARP EDGES AND
REMOVE BURRS

THIRD ANGLE PROJECTION

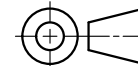

	NAME	SIGNATURE	DATE
DRAWN	BRENDAN HAMPSHIRE		2020-05-24
CHECKED			
APPROVED			

TITLE		CLAMP HANDLE AND PIVOT	
SIZE	DWG NO.		
A3	010	REV.	

SCALE	1:1	WEIGHT		SHEET	1 of 1
-------	-----	--------	--	-------	--------

6

5

4

3

2

1

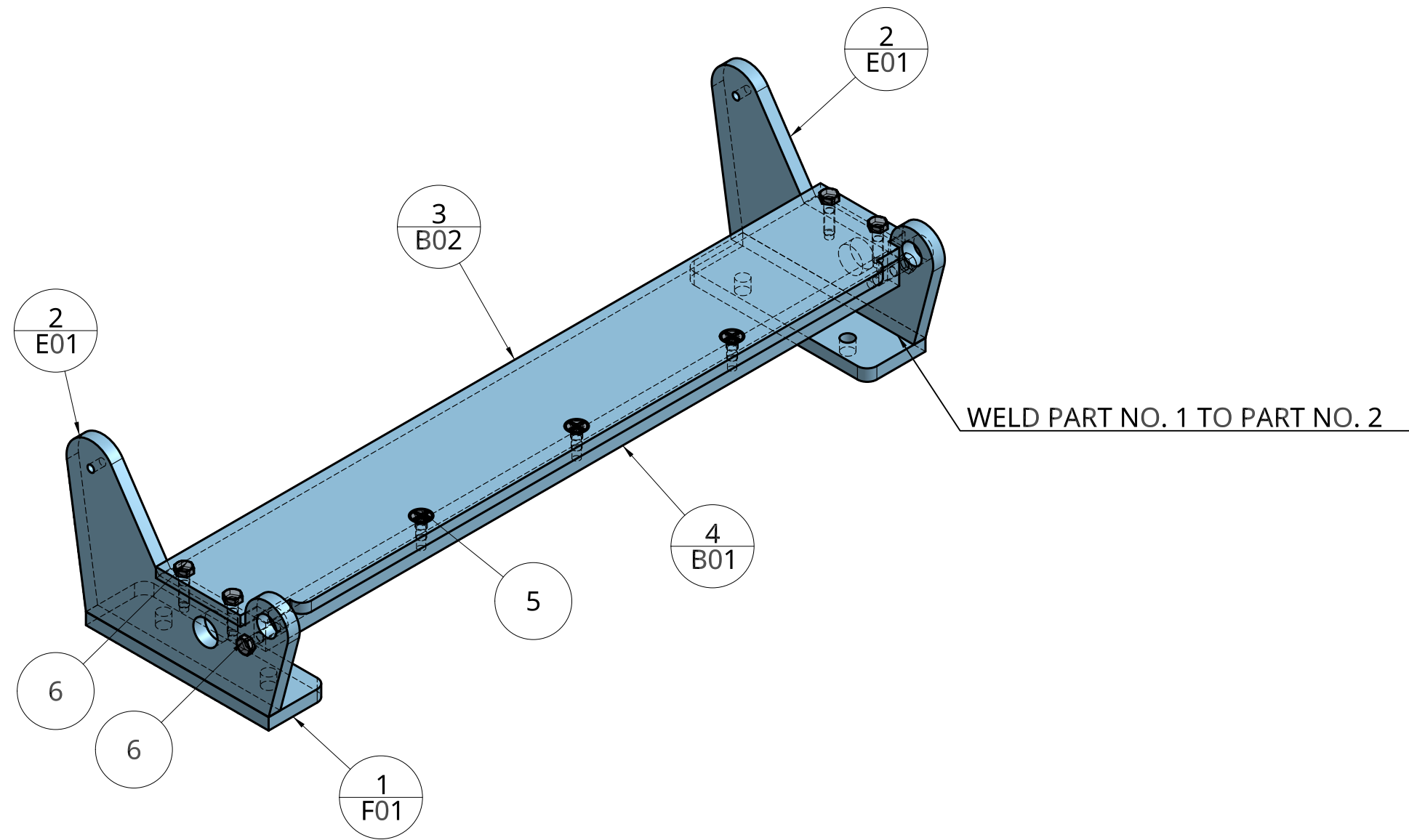

Item No.	Part number	Quantity	Name	Description
1	F01	2	Foot End Piece	Foot plate 12 mm thick
2	E01	2	End Piece	End plate - 12 mm thick
3	B02	1	Flat Bed	Bed Plate - 10 mm thick
4	B01	1	Bed Brace	Bed Brace - 12 mm thick
5		3	PH Countersunk flat head screw ISO 7046-1	Counter Sunk M8 x 20
6		6	Hex head bolt grade B ISO 4015	Hex Head M8 x 30

UNLESS OTHERWISE SPECIFIED, DIMENSIONS ARE IN MILLIMETERS

ANGULAR = ± °

SURFACE FINISH

DO NOT SCALE DRAWING

BREAK ALL SHARP EDGES AND REMOVE BURRS

THIRD ANGLE PROJECTION

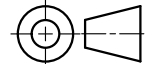

	NAME	SIGNATURE	DATE
DRAWN	BRENDAN HAMPSHIRE		2020-05-24
CHECKED			
APPROVED			

TITLE		BASE ASSEMBLY	
SIZE	DWG NO.		
A3	011	REV.	
SCALE	1:4	WEIGHT	SHEET 1 of 1

6 5 4 3 2 1

D

D

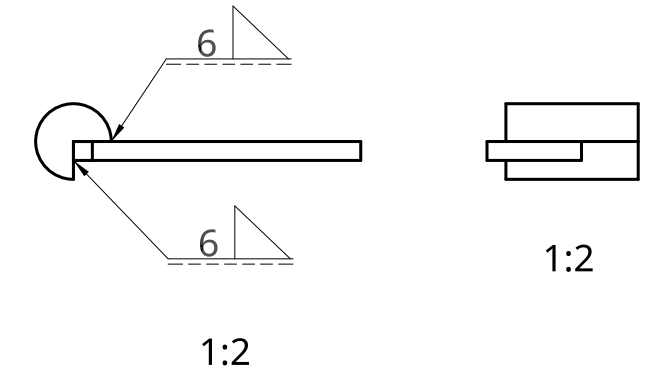
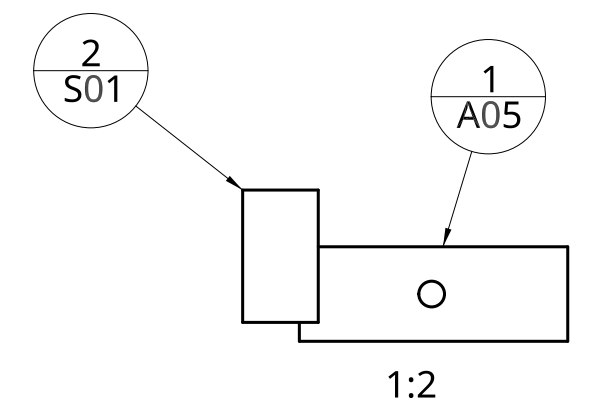
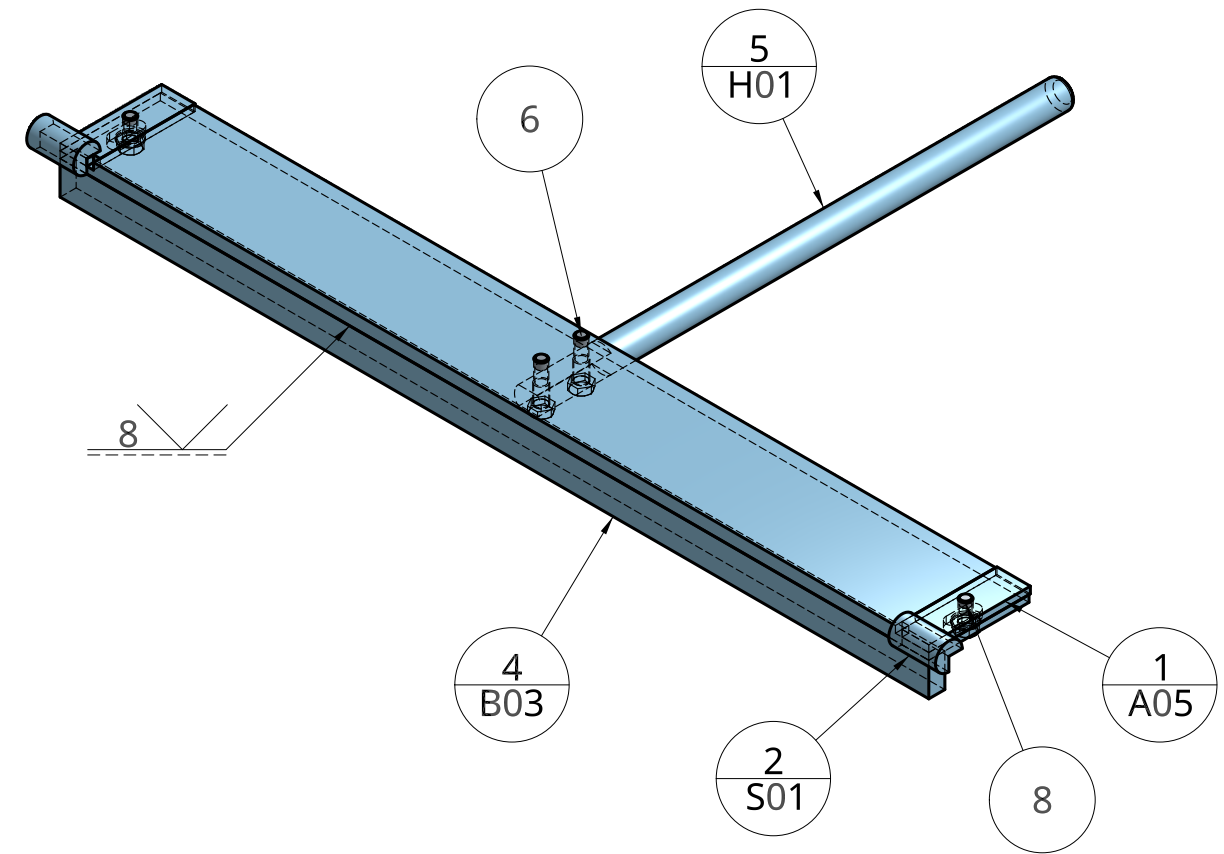

ONE AS SHOWN, ONE HANDED

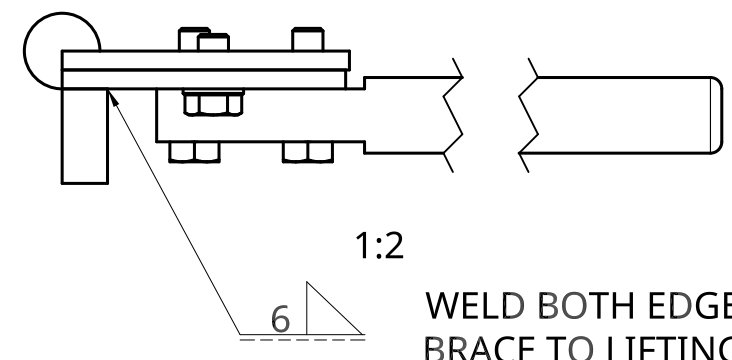

C

C

B

B

Item No.	Part number	Quantity	Name	Description
1	A05	2	Adjustment Plate	5 mm Thick plate
2	S01	2	3/4 Shaft	20 mm Dia Round Bar
3	L01	1	Lifting Plate	20 mm thick plate
4	B03	1	Bending Brace	12 x 25 mm Bar
5	H01	1	Bender Handle	20 mm Round Bar
6		2	Hex head bolt grade B ISO 4015	Hex Head M8 x 30
7		2	Chamfered plain washer normal M8	Chamfered plain washer normal M8 Steel
8		2	Hex head screw grade C M8x1.25 x 16	Hex head screw grade C M8x1.25 x 16 Stainless Steel

UNLESS OTHERWISE SPECIFIED, DIMENSIONS ARE IN MILLIMETERS

ANGULAR = ± °

SURFACE FINISH

DO NOT SCALE DRAWING

BREAK ALL SHARP EDGES AND REMOVE BURRS

THIRD ANGLE PROJECTION

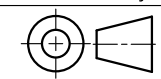

	NAME	SIGNATURE	DATE
DRAWN	BRENDAN HAMPSHIRE		2020-05-24
CHECKED			
APPROVED			

TITLE		BENDER ASSEMBLY	
SIZE	DWG NO.		
A3	012	REV.	
SCALE	WEIGHT	SHEET	1 of 1
1:4			

6 5 4 3 2 1

A

A

6

5

4

3

2

1

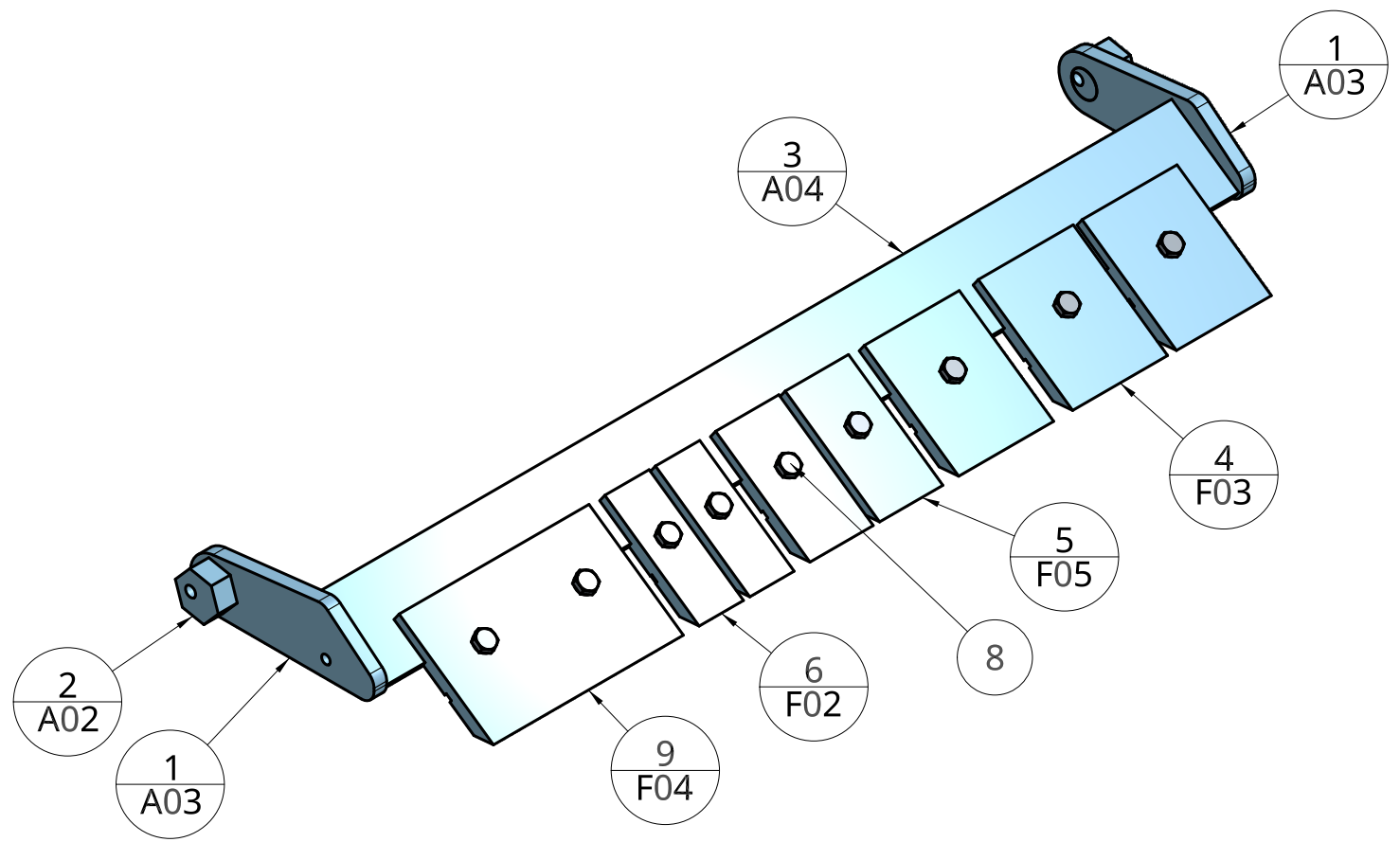

NOTE(S)

1. THE POSITION AND ROTATION AT WHICH THE ANGLE IS SET IN RELATION TO THE ARM IS KEY.
2. ADJUSTMENT WILL BE WASTED IF YOU GET THIS WRONG.
3. TACK ARMS TO ANGLE LAST AND CHECK ADJUSTMENT IS SUTABLE FOR YOUR APPLICATION ON THE COMPLETED ASSEMBLY.
4. DONT FUCK THIS UP.
5. POSITION THE ANGLE SIMILAR TO HOW ITS SHOWN BELOW.

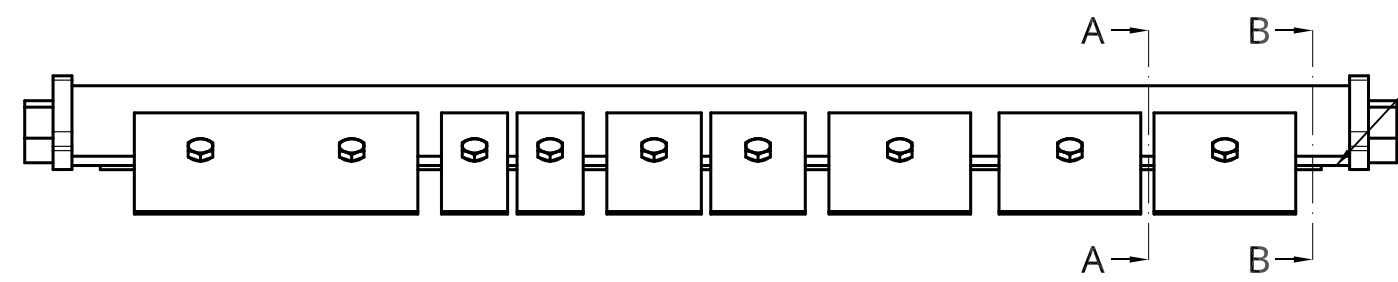

NOTE:
THE NOTCH AT THE
BACK IN THE ANGLE

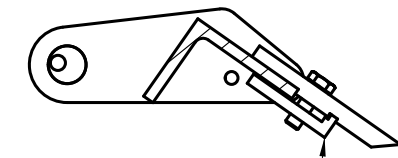

A - A

7
R01

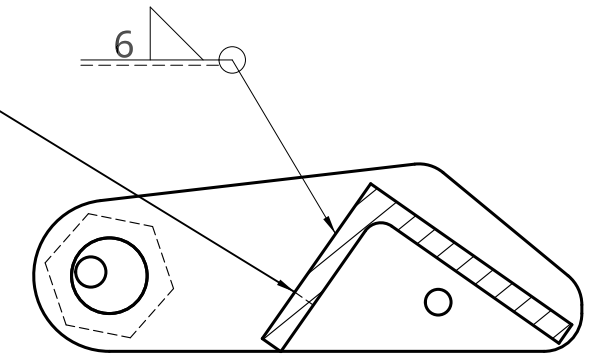

B - B
1:2

Item No.	Part number	Quantity	Name	Description
1	A03	2	Arm	10 mm thick plate
2	A02	2	Adjuster Nut	30 mm AF Hex Bar
3	A04	1	Unequal Angle	65 x 50 x 6 mm Angle
4	F03	3	75 mm finger	10 mm thick plate
5	F05	2	50 mm finger	10 mm thick plate
6	F02	2	35 mm finger	10 mm thick plate
7	R01	9	Finger retainer	10 mm thick plate
8		10	Hex head screw grade C M8x1.25 x 25	Hex head screw grade C M8x1.25 x 25 Steel
9	F04	1	150 mm finger	10 mm thick plate

UNLESS OTHERWISE SPECIFIED,
DIMENSIONS ARE IN MILLIMETERS

ANGULAR = ± °

SURFACE FINISH

DO NOT SCALE DRAWING

BREAK ALL SHARP EDGES AND REMOVE BURRS

FIRST ANGLE PROJECTION

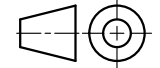

	NAME	SIGNATURE	DATE
DRAWN	BRENDAN HAMPSHIRE		2020-05-27
CHECKED			
APPROVED			

TITLE		CLAMP ASSEMBLY	
SIZE	DWG NO.		
A3	013	REV.	
SCALE	WEIGHT	SHEET	
1:4		1 of 1	

6

5

4

3

2

1

6

5

4

3

2

1

NOTE(S)

- 1. THIS ASSMEBLY IS FOR CLARITY ONLY.
- 2. TO BE ASSEMBLED INTO BASE ASSEMBLY.
- 3. CHECK ROTATING PARTS DO SO FREELY.
- 4. LIBERAL APPLICATION OF GREASE TO ALL MATING SURFACES, WE DON'T LIKE CHAFFAGE DO WE?

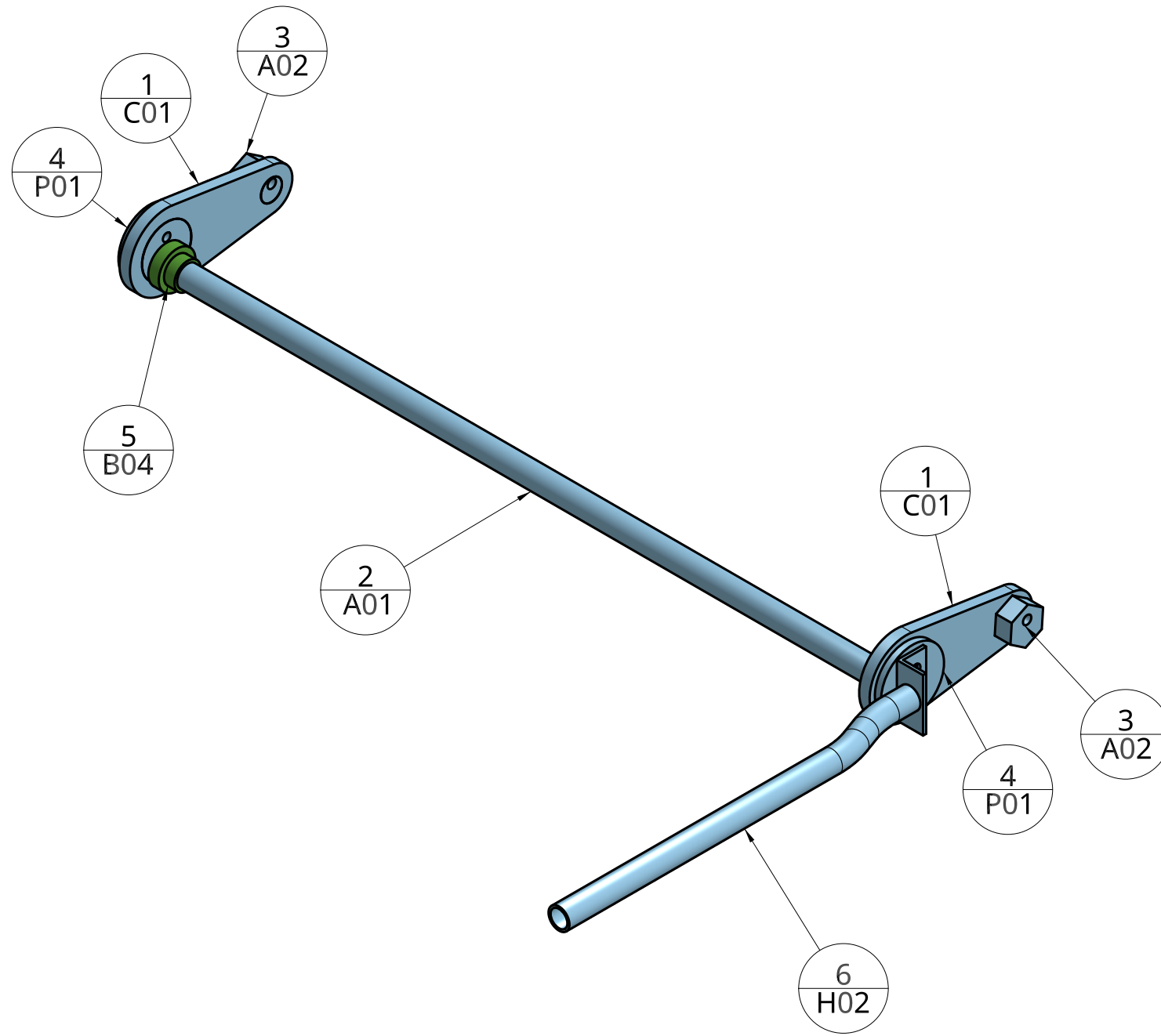

Item No.	Quantity	Part number	Name	Description
1	2	C01	Con rod	10 mm thick plate
2	1	A01	Axle	20 mm Dia Round Bar
3	2	A02	Adjuster Nut	30 mm AF Hex Bar
4	2	P01	Pivot	60 mm Dia Round Bar
5	2	B04	Bush	PLASTIC 35 mm Dia Round
6	1	H02	Clamp Handle	25 mm OD pipe and a bit of 3 mm plate

UNLESS OTHERWISE SPECIFIED, DIMENSIONS ARE IN MILLIMETERS

ANGULAR = ± °

SURFACE FINISH

DO NOT SCALE DRAWING

BREAK ALL SHARP EDGES AND REMOVE BURRS

	NAME	SIGNATURE	DATE
DRAWN	BRENDAN HAMPSHIRE		2020-05-27
CHECKED			
APPROVED			

TITLE		PIVOT ASSEMBLY	
SIZE	DWG NO.		
A3	014	REV.	
SCALE	1:4	WEIGHT	SHEET 1 of 1

6

5

4

3

2

1